



DESIGN AND TECHNOLOGY

9705/11

Paper 1

October/November 2013

3 hours

Additional Materials: Answer Booklet/A4 Paper
A3 Drawing Paper (2 sheets)
Extra sheets of A3 drawing paper for candidates who have used up both sides of their 2 sheets
A range of design drawing equipment



READ THESE INSTRUCTIONS FIRST

If you have been given an Answer Booklet, follow the instructions on the front cover of the Booklet.
Write your answers and working on the separate Answer Booklet/Paper provided.
Write your name, Centre number and candidate number on all the work you hand in.
Write in dark blue or black pen.
You may use a soft pencil, or coloured pencils/pens as appropriate, for any diagrams, graphs or rough working.
Do not use staples, paper clips, highlighters, glue or correction fluid.
DO NOT WRITE IN ANY BARCODES.

Section A

Answer **one** question on the Answer Booklet/A4 Paper provided.

Section B

Answer **one** question on the Answer Booklet/A4 Paper provided.

Section C

Answer **one** question on plain A3 paper.
Use **both** sides of the paper.
You may request additional sheets of A3 paper, but only if you have used up both sides of each of the 2 sheets provided.

You are advised to spend **30 minutes** on each of Sections A and B and **2 hours** on Section C.

At the end of the examination, fasten all your work securely together.
The number of marks is given in brackets [] at the end of each question or part question.
All dimensions are in millimetres.

This document consists of **10** printed pages and **2** blank pages.



Section A

Answer **one** question from this section on the Answer Booklet/A4 paper provided.

1 Fig. 1 shows a toy helicopter which is to be made in a school workshop.

(a) Give the name of:

(i) a suitable softwood that could be used to make part **A**; [1]

(ii) a suitable glue that could be used to join part **A** to the metal rod of part **B**. [1]

(b) Use notes and sketches to describe:

(i) how part **A** could be made and the edges of the softwood smoothed; [6]

(ii) how part **B** could be made and then attached to part **A**; [6]

(iii) how the two rotor blades could be made and then attached to part **A** in a way that allows them to rotate. [6]

You must give details about the tools, equipment and processes involved and the safety precautions that have to be undertaken at each stage.

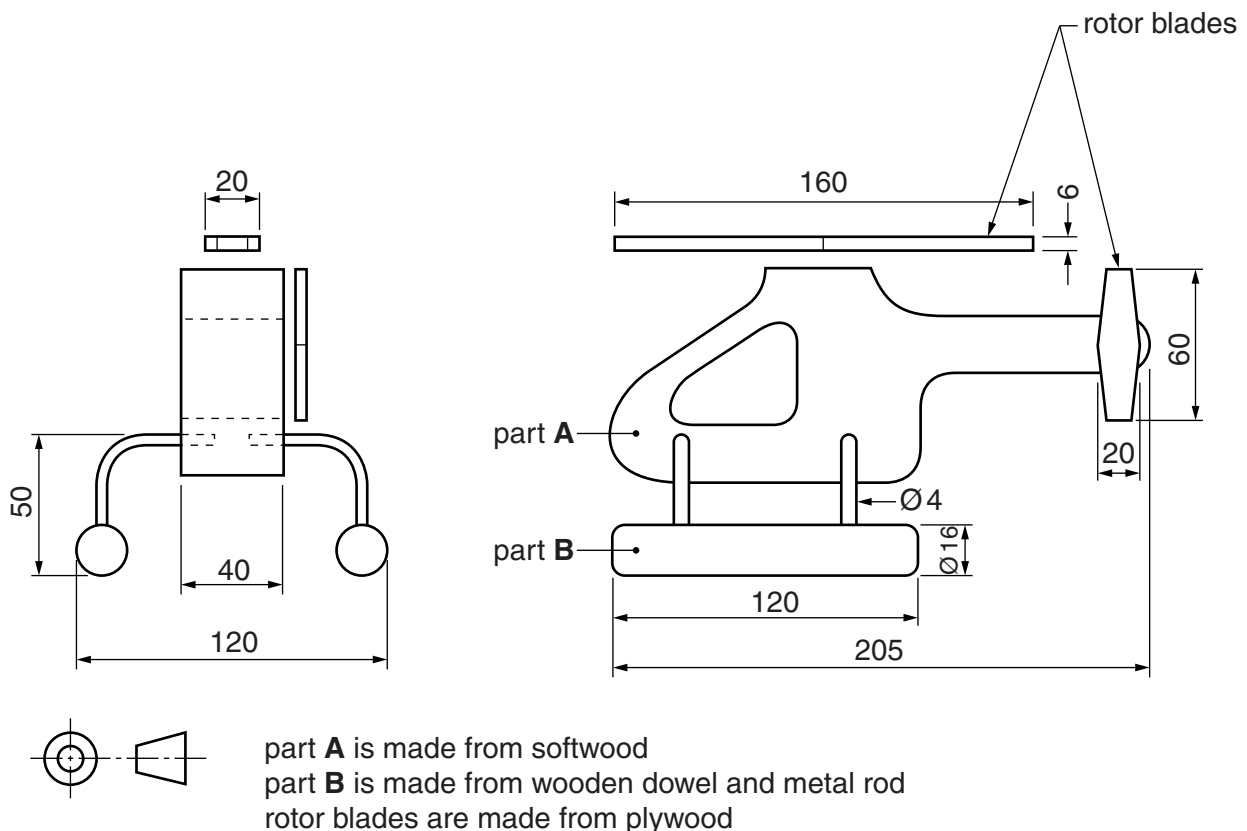

Fig. 1

- 2 Fig. 2 gives details about a fruit bowl which is to be made in a school workshop. The fruit bowl will be made from 30 lengths of 3 mm diameter metal rod which will be bent and then joined to a metal disc and a wooden base.

(a) The metal rod will need to be malleable.

Explain what is meant by malleable.

[2]

(b) Use notes and sketches to describe:

(i) how a jig could be made and used to bend one length of metal rod;

[6]

(ii) how the shape for the wooden base could be marked out and made;

[6]

(iii) how the 30 holes in the wooden base could be marked out and drilled.

[6]

You must give details about the tools, equipment and processes involved and the safety precautions that have to be undertaken at each stage.

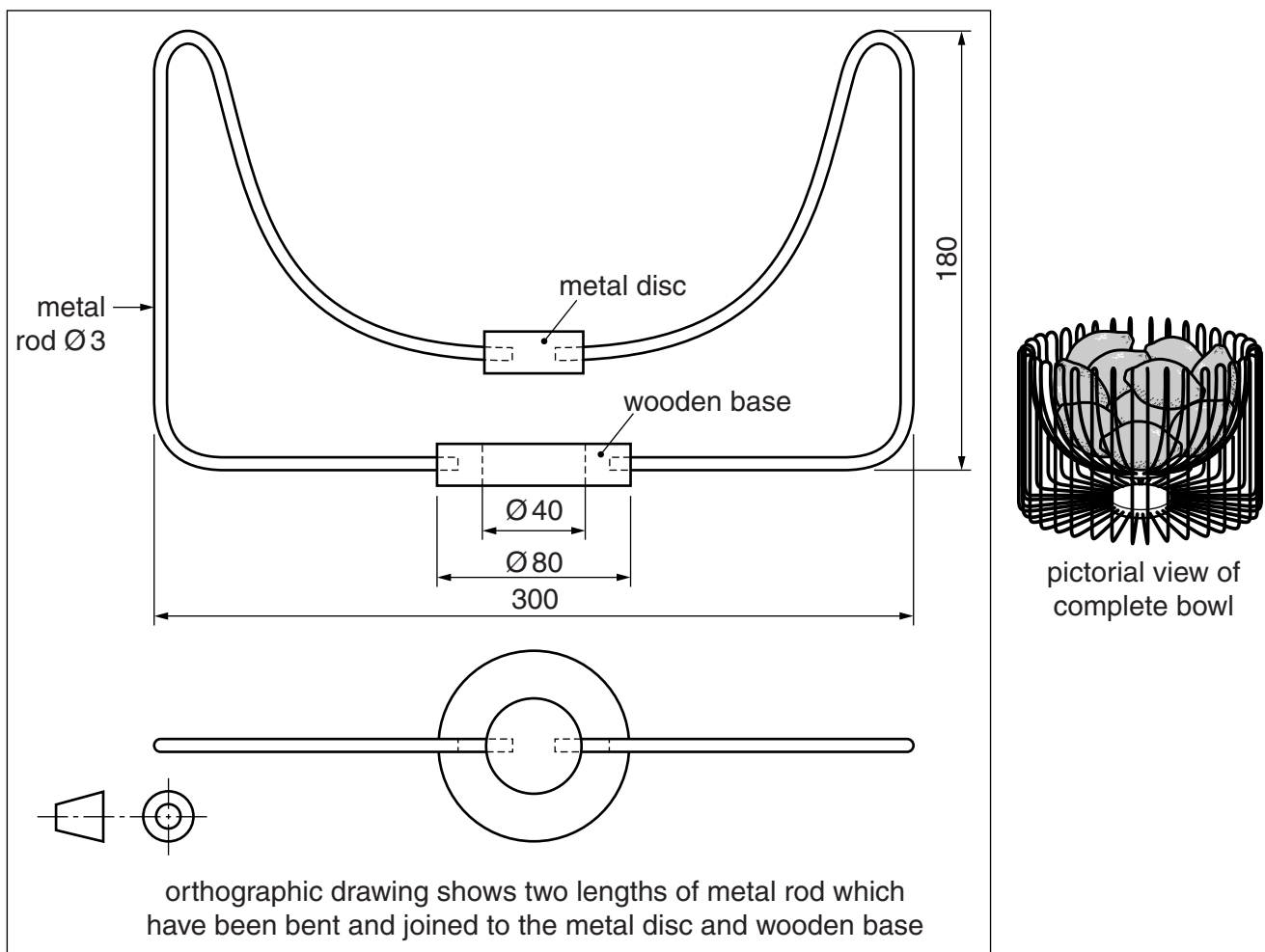

Fig. 2

- 3** Fig. 3 shows the three incomplete parts required to make a pop-up card with a V-fold mechanism. The two smaller pieces of card are glued onto the head of the lion to form a mouth. When the card is opened the mouth of the lion closes. The pop-up card will be made in a school workshop.

(a) The card is A5 in size. Use notes and a sketch to show how many A5 cards could be cut from an A2 sheet of card. [2]

(b) Use notes and sketches to describe:

- (i)** how CAD (Computer Aided Design) could be used to complete the drawing of the lion (both halves of the lion are the same); [6]
- (ii)** how the large part of the card could be laminated; [6]
- (iii)** how the two smaller pieces of card could be cut out, folded and then glued in their correct positions on the pop-up card. [6]

You must give details about the tools, equipment and processes involved and the safety precautions that have to be undertaken at each stage.

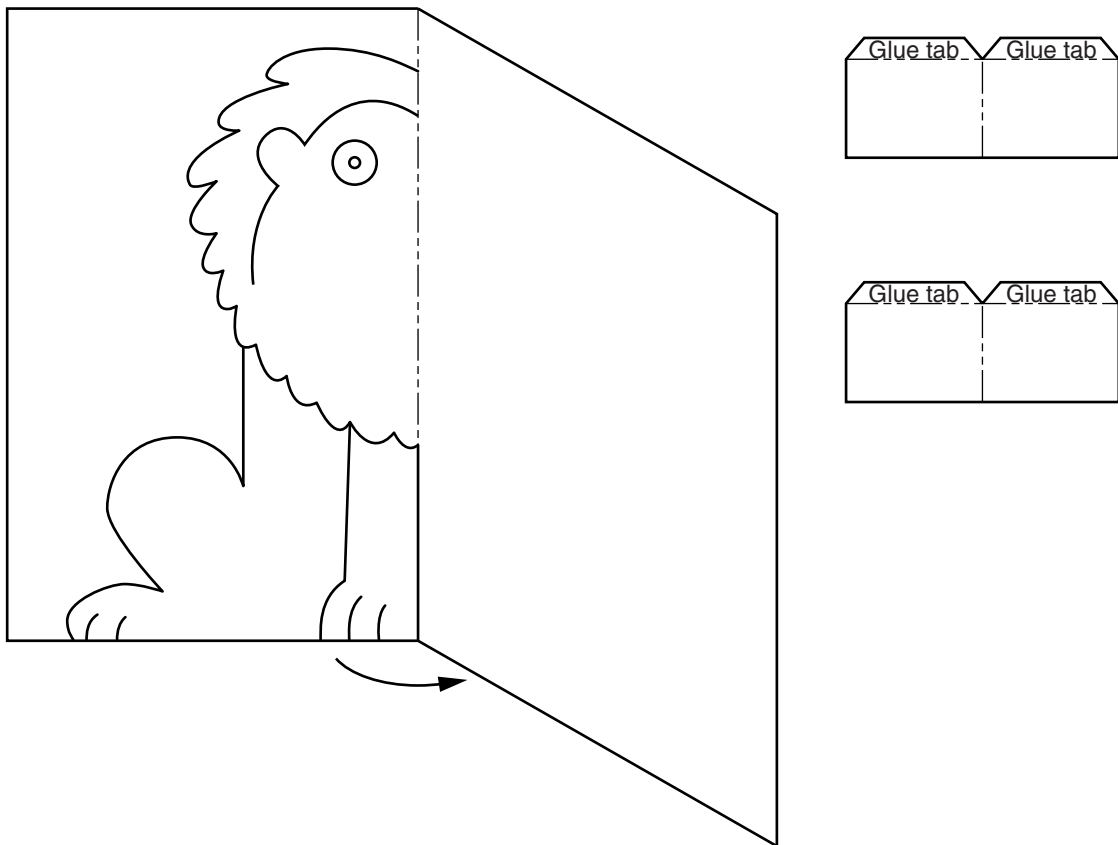

Fig. 3

Section B

Answer **one** question from this section on the Answer Booklet/A4 paper provided.

- 4 Fig. 4 shows a design for a card box, a bottle and a symbol that will be printed on the bottle. The box will package three of the bottles.
- (a) Explain what the symbol means. [2]
- (b) Identify and describe **two** problems with the design of the box. [4]
- (c) Using notes and sketches, explain how the design would need to be changed to overcome the two problems you have identified in (b). [6]
- (d) Discuss the significance of style and the influence of fashion when designing packaging for a new range of cosmetics aimed at the teenage market. [6]

Your answer should:

- (i) analyse the given situation and identify three relevant issues raised by the question; [3]
- (ii) explain why you consider these issues to be relevant; [3]
- (iii) contain specific examples/evidence to support your conclusions. [2]

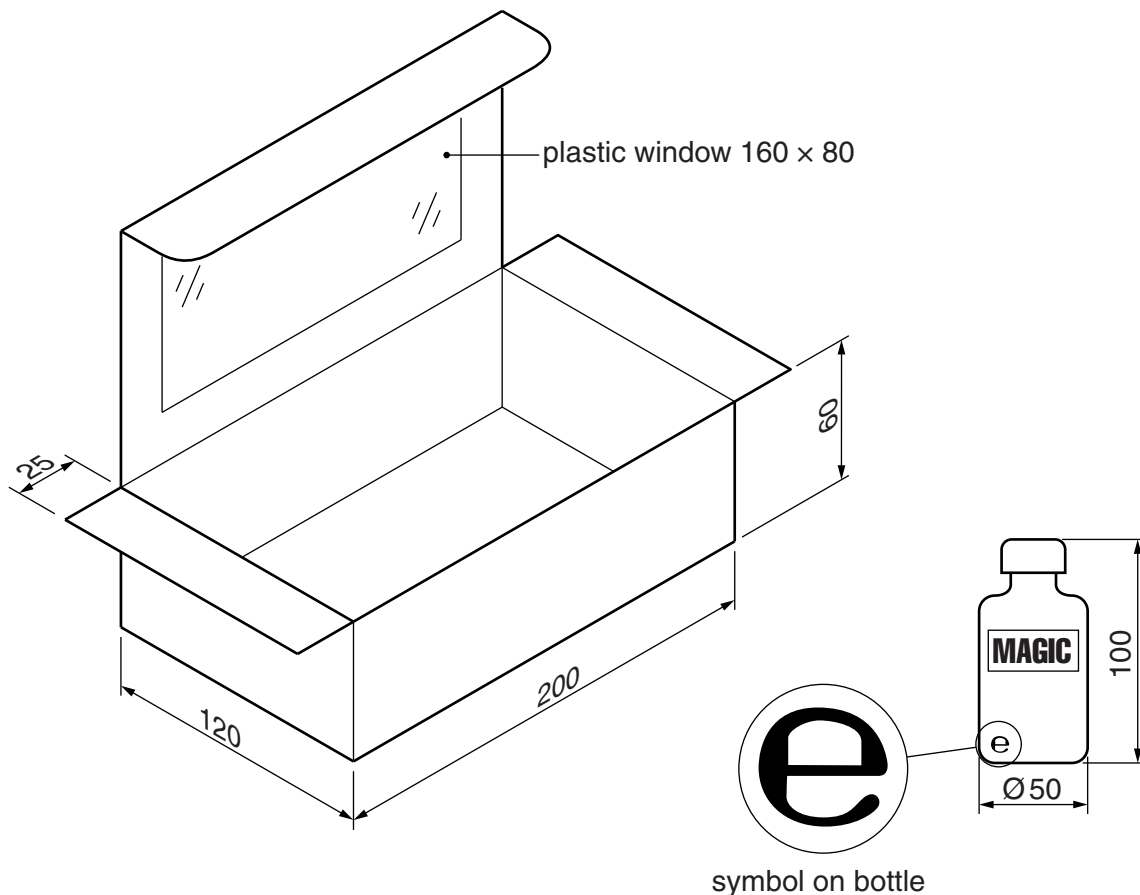

Fig. 4

5 Fig. 5 shows a design for a wooden gate, two gate posts and a label that will be attached to the gate when it is sold.

- (a) Explain what the symbol ® on the label means. [2]
- (b) Identify and describe **two** problems with the design of the gate. [4]
- (c) Using notes and sketches, explain how the design would need to be changed to overcome the two problems you have identified in (b). [6]
- (d) Discuss how and why timber resources are being conserved.

Your answer should:

- (i) analyse the given situation and identify three relevant issues raised by the question; [3]
- (ii) explain why you consider these issues to be relevant; [3]
- (iii) contain specific examples/evidence to support your conclusions. [2]

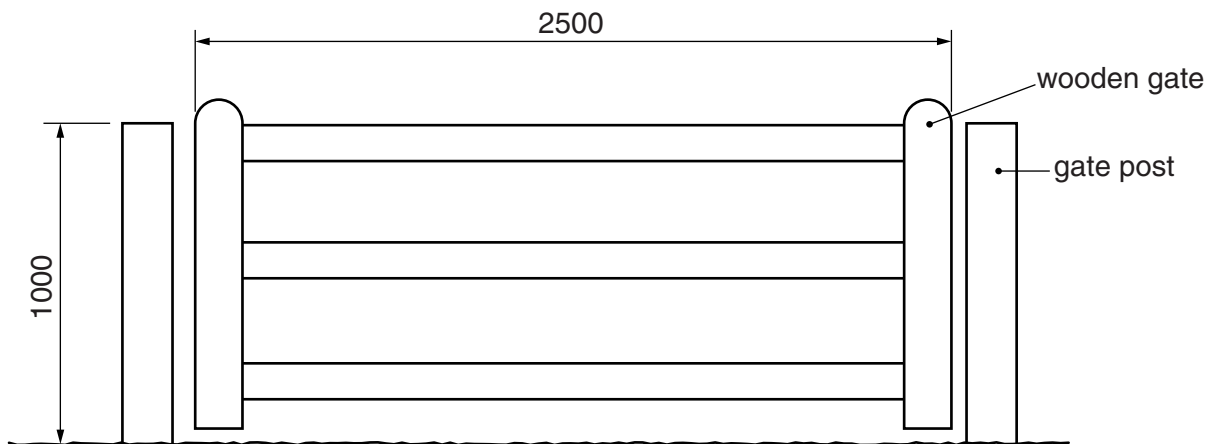

label

Fig. 5

6 Fig. 6 shows a design for a bus shelter.

- (a) Explain what the symbol means. [2]
- (b) Identify and describe **two** problems with the design of the bus shelter. [4]
- (c) Using notes and sketches, explain how the design would need to be changed to overcome the two problems you have identified in (b). [6]
- (d) Discuss what a designer would need to consider when selecting which materials would be suitable for a new bus shelter.

Your answer should:

- (i) analyse the given situation and identify three relevant issues raised by the question; [3]
- (ii) explain why you consider these issues to be relevant; [3]
- (iii) contain specific examples/evidence to support your conclusions. [2]

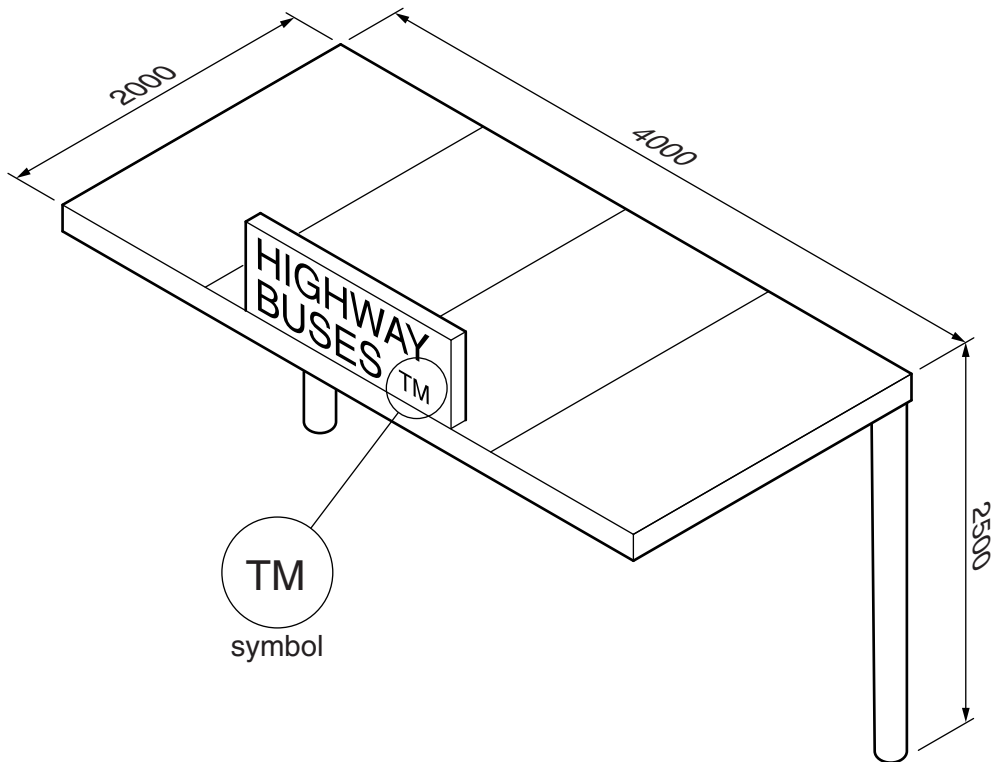

Fig. 6

Section C

Answer **one** question from this section on the plain A3 paper provided.

You are provided with two sheets of plain A3 paper. You should use **both** sides of the paper. **Each** of the four parts (a)–(d) of the question you choose to answer should take up one side of paper.

When you are asked to **develop** a design you must show, using notes and sketches, the development and evaluation of a **range** of ideas into a single design proposal. The design proposal should be annotated to give details about materials, joining methods and important sizes.

7 Fig. 7 shows an incomplete idea for an adjustable lamp.

- (a) Using notes and sketches, **develop** a design for a shade for the adjustable lamp. [20]
- (b) Using notes and sketches, **develop** a design for an arm which will be joined to part X and the shade you have designed in part (a). The design must allow the arm to be adjusted and fixed at different angles. [20]
- (c) Using notes and sketches, **develop** a design which allows the lamp to be clamped to a table. The design must include a way of joining the clamping device to part X. Part X must be able to rotate as shown in Fig. 7. [20]
- (d) Produce a pictorial rendered drawing of the complete adjustable lamp which shows all of the features that you have designed in (a)–(c). Do not include the table in this drawing. [20]

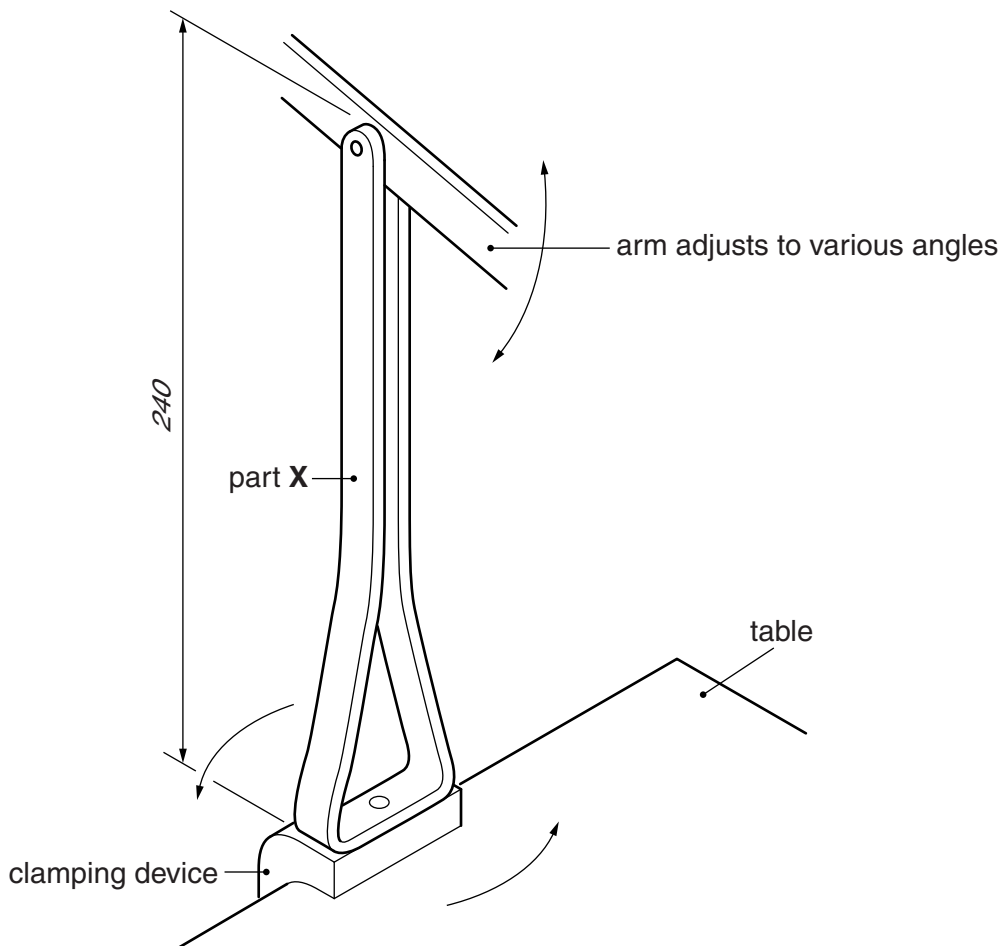

Fig. 7

8 Fig. 8 shows a cake and an incomplete idea for a card box which will package four of the cakes.

- (a) Using notes and sketches, **develop** a design for the card box. The box must be made from a one piece development (net) and have no more than one glued joint. It must be possible to open and securely close the box. [20]
- (b) Using notes and sketches, **develop** a design for the lettering to go on the box. The company's name will be 'Chris's Cakes' and the lettering should be in a style that reflects the name. [20]
- (c) Using notes and sketches, **develop** a design for a hand held rubber stamp that will be used to print the lettering that you have designed in (b) onto the card box. [20]
- (d) Produce pictorial rendered drawings of:
- (i) the complete card box which shows the features that you have designed in (a) and (b). The drawing must show the box open. Do not include the cakes in this drawing. [14]
- (ii) the hand held rubber stamp that you have designed in (c). [6]

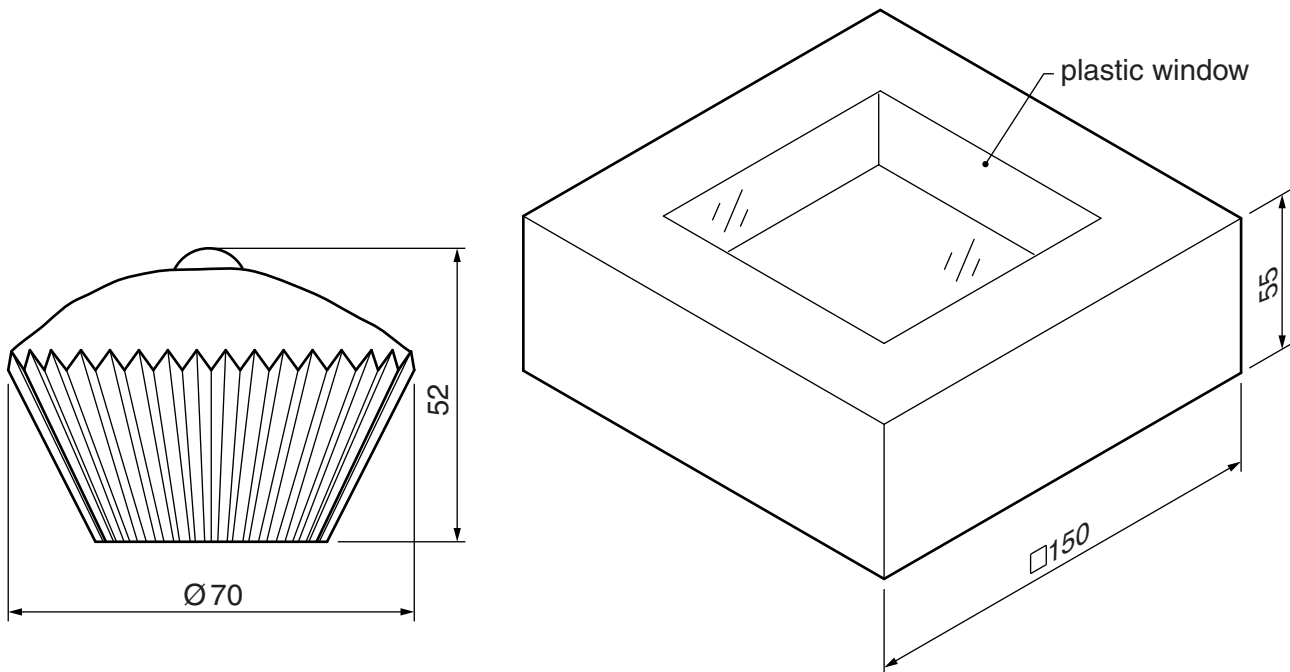

Fig. 8

- 9 Fig. 9 shows an incomplete idea for a toy shop which will be used by children aged 3–6 years old.
- (a) Using notes and sketches, **develop** a design which enables the four sides of the shop to be joined together and taken apart without the use of any tools. [20]
- (b) Using notes and sketches, **develop** a design for side **A** of the shop. [20]
- (c) Using notes and sketches, **develop** a design for side **B** of the shop. [20]
- (d) Produce a pictorial rendered drawing of the complete toy shop which shows all of the features that you have designed in (a)–(c).
The window, door and sales counter should all be shown open. [20]

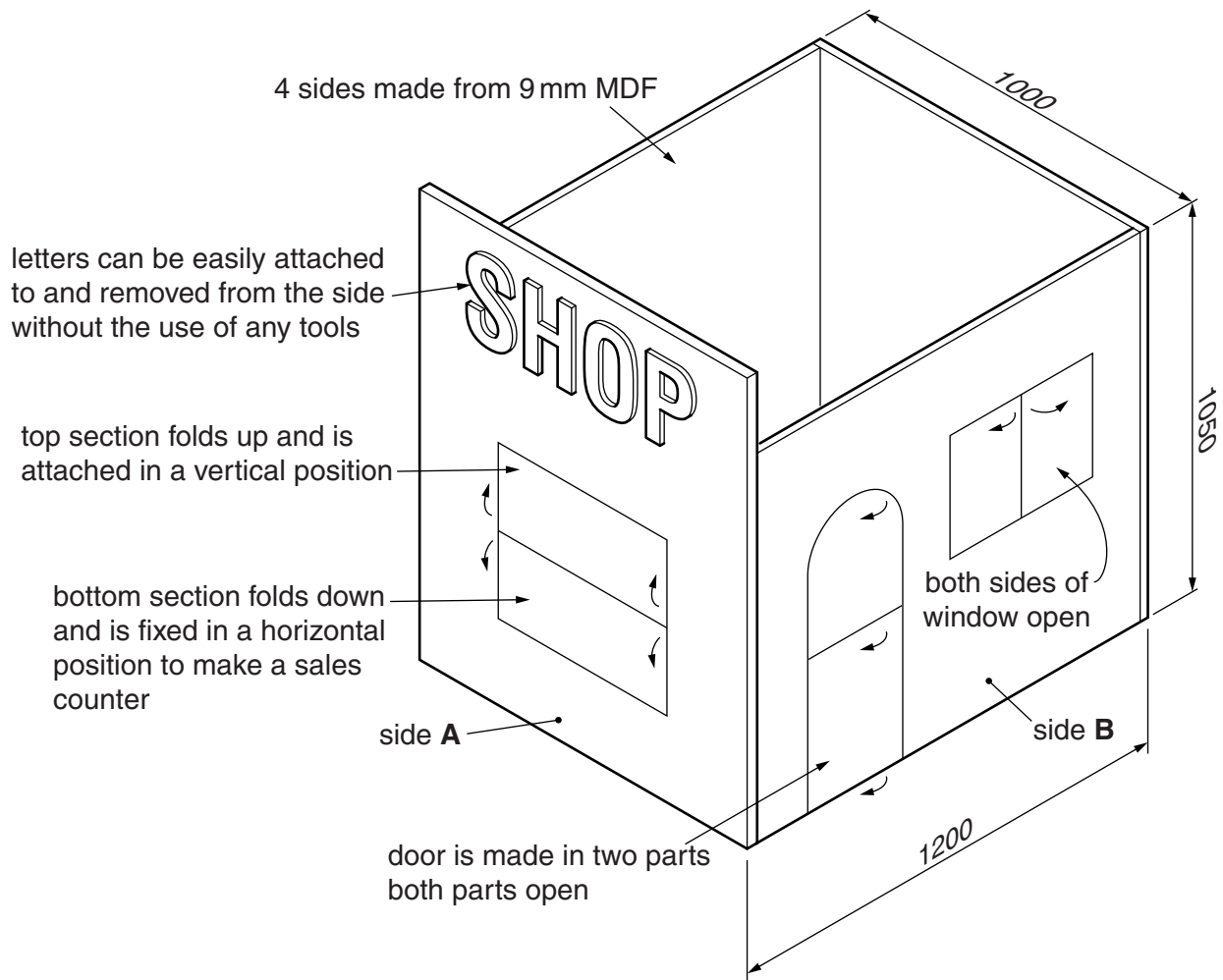

Fig. 9

BLANK PAGE

Permission to reproduce items where third-party owned material protected by copyright is included has been sought and cleared where possible. Every reasonable effort has been made by the publisher (UCLES) to trace copyright holders, but if any items requiring clearance have unwittingly been included, the publisher will be pleased to make amends at the earliest possible opportunity.

University of Cambridge International Examinations is part of the Cambridge Assessment Group. Cambridge Assessment is the brand name of University of Cambridge Local Examinations Syndicate (UCLES), which is itself a department of the University of Cambridge.